



Request for Quotations for Works

*BIDS FOR THE CONSTRUCTION OF ABLUTION FACILITIES (2 toilets) AT
ONGWEDIVA STADIUM*

**Procurement Reference No: W/RFQ/OngweTC-
10/2021/22**

*[Ongwediva Town Council, Private Bag 5549, Ongwediva, 065-233700, 065-
23052, jhainana@otc.com.na*

11 November 2021

Letter of Invitation

[Name and Address of Bidder:.....]

W/RFQ/OngweTC-10/2021/22

10 November 2021

Dear Sirs,

Request for Quotations for *-Bids for the Construction of Ablution facilities at Ongwediva sports stadium*

Ongwediva Town Council invites you to submit your best quote for the works described in detail hereunder.

Any resulting contract shall be subject to the terms and conditions referred to in the document.

Queries, if any, should be addressed to Josephine Hainana, Ongwediva Town Council, 065-233700.

Please prepare and submit your quotation in accordance with the instructions given or inform the undersigned if you will not be submitting a quotation.

Yours faithfully,

[Signature and Name of Head of Procurement Management Unit]

SECTION I: INSTRUCTIONS TO BIDDERS

1. Rights of Public Entity

Ongwediva Town Council reserves the right:

- (a) to split the contract as per the lowest evaluated cost per lot; and
- (b) to accept or reject any quotation or to cancel the quotation process and reject all quotations at any time prior to contract award.

2. Preparation of Quotations

You are requested to quote for the works mentioned in Section III, by completing, signing and returning:

- (a) the Quotation Letter in Section II with its annex for Bid Securing Declaration, where applicable;
- (b) the Priced Activity Schedule in Section IV;
- (c) the Specifications and Compliance Sheet in Section V; and
- (d) any other attachment as deemed appropriate

You are advised to carefully read the complete Request for Quotations document, including the Special Conditions of Contract in Section VII, before preparing your Quotation. The standard forms in this document may be retyped for completion but the Bidder is responsible for their accurate reproduction.

3. Validity of Quotations

The quotation validity period shall be *180* days from the date of bid submission deadline.

4. Eligibility Criteria

To be eligible to participate in this Quotation exercise, you should:

- (a) have a certified copy of a valid company Registration Certificate;
- (b) have a certified copy of or original valid good Standing Tax Certificate;
- (c) have a certified copy or an original valid good Standing Social Security Certificate;
- (d) have a valid certified copy of Affirmative Action Compliance Certificate, proof from Employment Equity Commissioner that bidder is not a relevant employer, or exemption issued in terms of Section 42 of the Affirmative Action Act, 1998;
- (e) have a certificate indicating SME Status (This bid is not reserved for SMEs);
- (f) Submit signed Bid-securing Declaration.
- (g) Submit a certified copy of a valid Fitness Certificate from any Local Authority in Oshana Region

5. Bid Security/Bid Securing Declaration

Bidders are required to subscribe to a Bid Securing Declaration for this procurement process.

6. Works Completion Period

The completion period for works shall be 30 days after acceptance and issue of Purchase Order. Deviation in completion period shall not be accepted.

7. Sealing and Marking of Quotations

Quotations should be sealed in a single envelope, clearly marked with the Procurement Reference Number, addressed to the Public Entity with the Bidder's name at the back of the envelope.

8. Submission of Quotations

Quotations should be deposited in the Quotation/Bid Box located at Ongwediva Town Council, not later than *09 March 2021, 14h30*. Quotations by post or hand delivered should reach Ongwediva Town Council by the same date and time at latest. Late quotations will be rejected.

Quotations received by e-mail will not be considered.

9. Opening of Quotations

Quotations will be opened internally by the Public Entity immediately after the closing time referred to in section 8 above. A record of the Quotation Opening stating the name of the bidders, the amount quoted, the presence or absence of a Bid Security/Bid Securing Declaration, will be posted on the website of the Public Entity and available to any bidder on request within three working days of the Opening.

10. Evaluation of Quotations

The Public Entity shall have the right to request for clarifications in writing during evaluation. Offers that are substantially responsive shall be compared on the basis of evaluated cost, subject to Margin of Preference where applicable, to determine the lowest evaluated quotation.

11. Technical Compliance

The Specifications and Compliance Sheet details the minimum specifications of the works to be carried out. The specifications have to be met, but no credit will be given for exceeding the specifications.

12. Prices and Currency of Payment

Prices for the execution of works shall be fixed in Namibian Dollars as quoted.

Quotations shall cover all costs of labour, materials, equipment, overheads, profits and all associated costs for performing the works, and shall include all duties. The whole cost of performing the works shall be included in the items stated, and the cost of any incidental works shall be deemed to be included in the prices quoted.

13. Award of Contract

The Bidder having submitted the lowest evaluated responsive quotation and qualified to perform the works shall be selected for award of contract. Award of contract shall be by issue of a Purchase Order/Letter of Acceptance in accordance with terms and conditions contained in Section VI: Contract Agreement and General Conditions of Contract.

14. Notification of Award and Debriefing

The Public Entity shall after award of contract promptly inform all unsuccessful bidders in writing of the name and address of the successful bidder and the contract amount and post a notice of award on its website within 7 days. Furthermore, the Public Entity shall attend to all requests for debriefing made in writing within 7 days of the unsuccessful bidders being informed of the award.

SECTION II

1. Technical requisition and Financial proposal

Interested parties with demonstrated experience, qualifications and competencies should submit their quotation. The weighting of the **Technical Requisition** shall be **70 %** and **Financial Proposal** shall be **30 %**.

2. Technical requisition

- a) In preparing the technical requisition, you are expected to examine all terms and instruction included in the bid document. Failure to provide all requested information will be at your own risk and may result in rejection of your proposal.
- b) During preparation of the technical requisition you must give particular attention to the following:
 - (i) If you consider that your firm does not have all the expertise for the Assignment, you may source a full range of expertise by entering into a Joint Venture with other firms or entities, including the other firms invited for this Assignment Subcontracting part of the Assignment to other Consultant.
 - (ii) The Estimated number of Key professional staff required for the Assignment.
 - (iii) Only Namibian registered companies that have an Office (with technical staff based there) and are operating in the Oshana Region will be considered for this work.

3. Financial Proposal

- a) The financial proposal should list the cost associated with the Assignment.
- b) The financial proposal shall be linked to the level of detail foreseen and presented in the Technical requisition.
- c) Payment for services by the professional team, from the inception of the project, shall be payable according to work done at each and every stage of the project.
- d) The validity of the bid shall be for the duration of the project. A rate presented in the financial proposal shall be considered fixed for the validity period of the bid, and the duration of the project.

4. Bid Process

- a) Bid document shall be accompanied by all proof and required documentation and a Financial Proposal.

5. Fee Structure

- a) For the purpose of this bid, all applicable fees with relevant rates must be clearly stated.
- b) Companies must make provision for the following key personnel on their project team (proof of qualification and experience in form of reference to be provided):
- **Contract Manager:** A qualified contract manager with any civil / construction or similar qualification and more than three years' experience in construction.
 - **Site supervisor:** A qualified site supervisor with any civil / construction or similar qualification and more than two years' experience.

6. Evaluation Criteria and Weighting

Responsive Corrected Prices

The Responsive Corrected Prices (CRPS) will be the prices of the bidders which are within the Margin Range of +/- 5% of Council's Estimate. Bidding prices falling outside the +/- 5% Margin Range of the Engineer's Estimate will be deemed financially unresponsive and will not be evaluated further to calculate the Bidder Index (BI).

Calculation of the Bidder Index

The Bidder Index (BI) for each compliant Bidder will be calculated per each Contract Area by weighted attributed using the formula below:

$$BI = 0.3 \times PS + 0.7 \times TS$$

Where:

PS = the Price Score for the Bidder under consideration, calculated per each Contract Area

TS = the Technical Score for the Bidder under consideration

The Price Score (PS) will be calculated for each Tenderer in accordance with the following formula:

$$Ps = (PC / PN) \times 100$$

Where: PC = Bidding Price of the lowest acceptable Bidder adjusted

PN = Biding Price under consideration adjusted in terms of bidding Price of the

lowest acceptable Bidder

Provided that the Bid is substantially responsive, the Employer shall correct arithmetical errors on the following basis:

(a) Only for unit price contracts, if there is a discrepancy between the unit price and the total price that is obtained by multiplying the unit price and quantity, the unit price shall prevail and the total price shall be corrected, unless in the opinion of the Employer there is an obvious misplacement of the decimal point in the unit price, in which case the total price as quoted shall govern and the unit price shall be corrected;

(b) If there is an error in a total corresponding to the addition or subtraction of subtotals, the subtotals shall prevail and the total shall be corrected; and

(c) If there is a discrepancy between words and figures, the amount in words shall prevail, unless the amount expressed in words is related to an arithmetic error, in which case the amount in figures shall prevail subject to (a) and (b) above.

The Technical Score will be calculated for each Bidder in accordance with the following formula:

$$TS = (TX + TC + TM + TD)$$

Criteria, sub-criteria, and point system for the evaluation of Full Technical Simplified and Proposals are:

ITEM	NON-PRICE ATTRIBUTES TECHNICAL / CAPACITY / PDN ATTRIBUTES	MAX. POINTS
T_x	Company Relevant Experience Comply with Similar Experience Requirements <ul style="list-style-type: none"> ▪ References / Completion Certificates <ul style="list-style-type: none"> 1 Reference of civil construction= 15 2 References of civil construction = 25 >3 References of civil construction = 35 	35
T_c	Relevant Competence: Staff (<i>Contract of Agreement between Employee & Employer</i>) <ul style="list-style-type: none"> ▪ Contract Manager <ul style="list-style-type: none"> 1 Year experience = 5 >2 Years' experience = 15 ▪ Site Supervisor <ul style="list-style-type: none"> With Experience in civil/ structural work 1 Year experience = 5 > 2 Years' experience = 10 	25

T_M	Qualification Proof of qualifications for a Contract Manager=15 Proof of qualifications for a Site supervisor =10	25
T_D	Fitness certificate ▪ From Oshana region based Namibian registered companies.	15
T_s	Technical Score	100

SECTION III: QUOTATION LETTER

(to be completed by Bidders)

*[Complete this form with all the requested details and submit it as the first page of your quotation with the Priced Activity Schedule and documents requested above. A signature and authorisation on this form will confirm that the terms and conditions of the RFQ prevail over any attachments. **If your quotation is not authorised, it will be rejected***

Quotation addressed to: <i>[name of Public Entity]</i>	
Procurement Reference Number:	
Subject matter of Procurement:	

We offer to execute the Works detailed in the Statement of Requirements, in accordance with the terms and conditions stated in your Request for Sealed Quotations referenced above.

We confirm that we are eligible to participate in this Quotation exercise and meet the eligibility criteria specified in Section 1: Instructions to Bidders

We undertake to abide by the Conduct of Bidders and Suppliers as provided under the Public Procurement Act during the procurement process and the execution of any resulting contract.

We have read and understood the content of the Bid Securing Declaration (BSD) attached hereto and subscribe fully to the terms and conditions contained therein. We further understand that this subscription could lead *[forfeiture of the security amount / disqualification on the grounds mentioned in the BDS]*

The validity period of our Quotation is _____ days *[insert number of days]* from the date of the bid submission deadline.

We confirm that the prices quoted in the Priced Activity Schedule are fixed and firm and will not be subject to revision or variation, if we are awarded the contract **prior to the expiry** date of the quotation validity.

Works will commence within _____ [*insert number*] days from date of issue of Purchase Order/ Letter of Acceptance.

Works will be completed within _____ [*insert number*]days from date of issue of Purchase Order/ Letter of acceptance.

Quotation Authorised by:

Name of Bidder		Company's Address and seal	
Contact Person			
Name of Person Authorising the Quotation:		Position:	Signature:
Date		Phone No./E-mail	

BID SECURING DECLARATION
(Section 45 of Act)
(Regulation 37(1)(b) and 37(5))

Date: *[Day/month/year]*.....

Procurement Ref No.:

To: *[insert complete name of Public Entity and address]*.....

I/We* understand that in terms of section 45 of the Act a public entity must include in the bidding document the requirement for a declaration as an alternative form of bid security.

I/We* accept that under section 45 of the Act, I/we* may be suspended or disqualified in the event of

- (a) a modification or withdrawal of a bid after the deadline for submission of bids during the period of validity;**
- (b) refusal by a bidder to accept a correction of an error appearing on the face of a bid;**
- (c) failure to sign a procurement contract in accordance with the terms and conditions set forth in the bidding document, should I/We* be successful bidder; or**
- (d) failure to provide security for the performance of the procurement contract if required to do so by the bidding document.**

I/We* understand this bid securing declaration ceases to be valid if I am/We are* not the successful Bidder

Signed:
[insert signature of person whose name and capacity are shown]

Capacity of:
[indicate legal capacity of person(s) signing the Bid Securing Declaration]

Name:
[insert complete name of person signing the Bid Securing Declaration]

Duly authorized to sign the bid for and on behalf of: *[insert complete name of Bidder]*

Dated on _____ day of _____, _____
[insert date of signing]

Corporate Seal (where appropriate)

[Note: In case of a joint venture, the bid securing declaration must be in the name of all partners to the joint venture that submits the bid.]*

**delete if not applicable / appropriate*

SECTION IV: STATEMENT OF REQUIREMENTS

Bill of Quantities¹

Procurement Reference No: **W/RFQ/OngweTc-10/2021/22**

SCHEDULE OF QUANTITIES					
CONSTRUCTION OF 2X ABLUTION FACILITIES AT ONGWEDIVA STADIUM					
ITEM	DESCRIPTION	UNIT	QTY	RATE (N\$)	AMOUNT
	SECTION 1: PRELIMINARY & GENERAL				
1.0	CONTRACTOR'S ESTABLISHMENT ON SITE	Sum	1		
1.1	Contractor's General Obligation				
1.1.1	a) Fixed obligations	Sum	1		
1.1.2	b) Tests carried out by independent Laboratory	Prov. Sum	1	5000.00	5000.00
	-				
1.1.3	c) Handling costs and profit in respect of item 1.1.2	%	5000		
TOTAL CARRIED TO SUMMARY					

¹ In lump sum contracts, the "Bill of Quantities" is prepared for information; it is not contractual. The contractual document prepared by the Bidder shall be a "Schedule of Activities."

ITEM	DESCRIPTION	UNIT	QTY	RATE (N\$)	AMOUNT
	SECTION 2: 2x Toilets				
2.1	<u>EARTHWORKS</u>				
2.1.1	<i>Site clearance</i>				
2.1.2	Digging up and removing rubbish, debris, top soil not exceeding	m ²	45.33		
2.2	<u>CONCRET WORK</u>				
2.2.1	Foundation	m ³	1.8		
2.2.2	Apron	m ³	6.8		
2.3	<u>MANSORY</u>				
2.3.1	Brickwork	m ²	36.5		
2.3.2	Plastering	m ²	65.3		
2.3.3	Floor Tiling	m ²	7.32		
2.4	<u>STRUCTURAL WORK</u>				
	Roofing and metal work	m ²	10.32		
	Ceiling	m ²	7.32		
2.5	<u>PAINT WORK</u>				
2.5.1	Painting	m ²	65.3		
2.6	<u>STEEL WORK</u>				
2.6.1	Glazing (metal work doors, window etc)				
2.7	<u>PLUMBING WORK</u>				
2.7.1	Sewer connection				
2.7.2	Water reticulation(drinking)				
2.8	<u>ELECTRICAL INSTALLATION</u>				
2.8.1	Lighting (internal and external)				
	TOTAL CARRIED TO SUMMARY				
	SECTION 3: SEPTIC TANK				
3.1	<u>EARTHWORKS</u>				
3.1.1	<i>Site clearance</i>				
3.1.2	Digging up and removing rubbish, debris, top soil not exceeding girth 1.5m	m ²	14.4		
3.2	<u>CONCRETE WORK</u>				

3.2.1	Concrete cast	m ³	10.12		
3.3	<u>STRUCTURAL WORK</u>				
	Steel reinforcement	m ²	67.4		
3.4	<u>STEEL WORK</u>				
3.4.1	Glazing (metal closing lid, etc)				
3.5	<u>PLUMBING WORK</u>				
3.5.1	Sewer connection				
	SECTION 4: SOAK PIT				
4.1	<u>EARTHWORKS</u>				
4.1.1	<i>Site clearance</i>				
4.1.2	Digging up and removing rubbish, debris, top soil not exceeding girth 1.5m	m ²	5		
4.2	<u>CONCRET WORK</u>				
4.2.1	Concrete cast	m ³	4.4		
4.3	<u>STRUCTURAL WORK</u>				
	Steel reinforcement	m ²	30		
4.4	<u>STEEL WORK</u>				
4.4.1	Glazing (metal closing lid, etc)				
4.5	<u>PLUMBING WORK</u>				
4.5.1	Sewer connection				
	TOTAL CARRIED TO SUMMARY				

SECTION	DESCRIPTION	
1	PRELIMINARY AND GENERAL	
2	TOILETS	
3	SEPTIC TANK	
4	MISCELLANEOUS	
	SUBTOTAL (1)	
	ADD: 10% CONTINGENCY	
	<i>Note: Allow 10% of Subtotal (1) for general contingencies to be used as directed by the Town Engineer and to be deducted in part or whole if not required</i>	
	SUBTOTAL (2)	
	ADD: 15% VAT	
	TOTAL CONSTRUCTION COST	

**SECTION V:
SCOPE OF WORKS, SPECIFICATIONS AND PERFORMANCE
REQUIREMENTS**

The contract for the construction of ablution facilities at Ongwediva sports stadium: These performance requirements should be read in conjunction with the Bill of Quantities.

1. Foundation (Excavation, Filling Compaction, Concrete) - 250mm cement/sand screed to be laid on 100mm concrete slab on, well-compacted hardcore. Footings for 110mm walls to be 230mm x 600mm and footings for 220mm walls are to be 230mm x 800mm. Minimum foundation to be 700mm. Topsoil to be cleared to a depth of 250mm.
2. Floor and Floor Covering - Filling, Compaction, Concrete with rough surface. Ceramic floors tiles to be provided and installed.
3. Superstructure - 7 MPA Super bricks to be used with reinforcement. Plastering on internal and external walls.
4. Painting - One coat PVA acrylic emulsion wall paint on internal walls (SABS approved). External wall paint (SABS approved). Colour to be provided after the award of contract.
5. Windows, window frames and window panes - Window frame Type NE1 to be used with clear frosted window panes.
6. Door frames, steel doors and locksets - Both interior and external doors shall be standard steel doors and frames combination, complete with handles and locksets.
7. Roof Structure - Flat Roof sloping as specified on the drawings. IBR Roof Sheeting (0,4mm) screwed onto 100x50x20x2,0 Lipped Channels. Facial boards are to be provided on the roof edges.
8. Electrical - 15mm PVC conduit, chipped into the walls, complete with internal and external lights, light fittings and flush wall switches for the six (6) internal lights and one (1) weather proof surface mounted switch for the two (2) external lights. Cables and cabling included.

9. W.C. Pans, Hand Wash Basins and Sanitary Fittings - White, ceramic low level washdown W.C pan, white ceramic hand wash basin with a single pillar tap (Cobra); complete with all the fittings. Toilet paper holder.
10. Wall Tiles - Ceramic wall tiles to be installed above the hand wash basin (600mm x 600mm for each hand wash basin).
11. Septic Tank - to be constructed with 7 MPA Super Bricks with a vent pipe (110mm) and a manhole frame complete with a cover as illustrated in the drawing.

B. DRAWINGS

See Drawings Number: attached.

SECTION VI: PRICED ACTIVITY SCHEDULE

Procurement Reference Number: _____

[Complete the unit and total prices for each item listed below. Authorise the prices quoted in the signature block below.]

The quantities shown below are approximate and not subject to re-measurement for payment purposes.

Item No	Brief Description of Works	Quantity	Unit of Measure	Unit Price (N\$)	Total Price (N\$)
A*	B*	C*	D*	E	F
1	Contractor's general obligation	Refer to BoQ			
2	Earth works	Refer to BoQ			
3	Concrete work	Refer to BoQ			
4	Masonry	Refer to BoQ			
5	Structural work	Refer to BoQ			
6	Steel work	Refer to BoQ			
7	Plumbing work	Refer to BoQ			
8	Electrical installation	Refer to BoQ			
9	Septic tank	Refer to BoQ			
10	sundries	Refer to BoQ			

Enter 0% VAT rate if VAT exempt.

Subtotal	
VAT @ %	
Total	

*Columns A to D to be completed as applicable by the Public Entity

Priced Activity Schedule Authorised By:

Name:		Signature:	
Position:		Date:	
Authorised for and on behalf of:	Company		

SECTION VII: SPECIFICATIONS AND COMPLIANCE SHEET

[Public Entity shall customise this section and the table hereunder where the Service Providers have to achieve set specification and performance standards.]

Procurement Reference Number: _____

[Bidders should complete columns C and D with the specifications and performance of the Works offered. Also state “comply” or “not comply” and give details of any non-compliance/deviation to the specifications required. Attach detailed technical literature if required. Authorise the specifications offered in the signature block below]

Item No	Specifications and Performance Required	Compliance of Specifications and Performance Offered	Details of Non-Compliance/ Deviation (if applicable)
A*	B*	C	D

* Columns A and B to be completed by Public Entity.

Specifications and Compliance Sheet Authorised By:

Name:		Signature:	
Position:		Date:	
Authorised for and on behalf of:		Company	

+

SECTION VIII SPECIAL CONDITIONS OF CONTRACT

Procurement Reference Number: _____

The clause numbers given in the first column correspond to the relevant clause number of the General Conditions of Contract. *[This section is to be customised by the Public Entity to suit the requirements of the specific procurement].*

GCC Clause Reference	Special Conditions
Employer GCC 1.1(r)	Ongwediva Town Council
Intended Completion Date GCC	The intended completion date is: 30 February 2022
Project Manager GCC 1.1(y)	The Project Manager is: The works will be supervised by Ongwediva Town Council's Technical Team
Site GCC 1.1(aa)	The Site is located at Ongwediva Sports stadium
Start Date GCC 1.1(dd)	The Start Date shall be: 15 January 2022
The Works GCC 1.1(hh)	The Works consist of: Demolitions, Earthworks, Concrete Works, Painting, Plumbing, Bedding, Pipe Work, Shade ports.
Interpretation GCC 2.2	The project will be completed in the following sections: _____
Interpretation GCC2.3	The following additional documents shall form part of the contract: _____
Language and Law GCC 3.1	The language of the contract is English The law that applies to the Contract is the law of Namibia.
Project Manager's Decisions 4.1	The Project Manager shall obtain specific approval from the Employer before carrying out any of his duties under the Contract which in the Project Manager's opinion will cause the amount finally due under the Contract to exceed the Contract Price or will give entitlement to extension of time. This requirement shall be waived in an emergency affecting safety of personnel or the Works or adjacent property.

GCC Clause Reference	Special Conditions
<p>Notices GCC 6</p>	<p>Any notice shall be sent to the following addresses: For the Employer, the address shall be as given on the page 2 of this Bidding Document and the contact name shall be Ms. Josephine Hainana For the Contractor, the address shall be as given on the first page of the Purchase Order/Letter of Acceptance and the contact name shall be _____</p>
<p>Insurance GCC 13.1</p>	<p>Except for the cover mentioned in (d)(i) hereunder, the other insurance covers shall be in the joint names of the Contractor and the Employer and the minimum insurance amounts shall be:</p> <ul style="list-style-type: none"> (a) for the Works, Plant and Materials: <i>(for the full amount of the works including removal of debris, professional fee etc...)</i> (b) for loss or damage to Equipment: <i>(for the replacement value of the equipment that the contractor intends to use on site until the taking over by the Employer.</i> (c) for loss or damage to property (except the Works, Plant, Materials, and Equipment) in connection with Contract <i>for an amount representing the value of the properties that are exposed to the action of the contractor in the execution of the works. It will extend to the property of the Procuring Entity as well).</i> (d) for personal injury or death: <ul style="list-style-type: none"> (i) of the Contractor's employees: <i>[The Contractor shall take an adequate insurance cover for its employees for any claim arising in the execution of the works].</i> (ii) of other people: <i>[This cover shall be for an adequate amount for Third Party extended to the Employer and its representatives].</i> (e) for loss or damage to materials on-site and for which payment have been included in the Interim Payment Certificate, where applicable. <p>The Contractor shall choose to take the insurance covers indicated above as separate covers or a combination of the Contractor's All Risks coupled with the Employer's liability and First Loss Burglary, after approval of the Employer. All insurance covers shall be of nil or the minimum possible deductibles at sole expense of the contractor.</p>

GCC Clause Reference	Special Conditions
Site Date GCC 14.1	The site Data shall be:
Possession of the Site GCC 20.1	The Site Possession Date shall be:
Procedure for Disputes GCC 24	No Adjudicator shall be appointed under the contract and arbitration shall not apply. If any dispute arises between the Employer and the Contractor in connection with or arising out of the Contract, the parties shall seek to resolve any such dispute by amicable agreement. If the parties fail to resolve such dispute by amicable agreement, within 14 days after one party has notified the other in writing of the dispute, then the dispute shall be referred to court by either party.
Program GCC 25.1	The Contractor shall submit for approval a Program for the Works within days from the date of the Letter of Acceptance or issue of Purchase Order Agreement.
GCC 25.3	Program updates <i>shall</i> be required
Defects Liability Period GCC 33.1	The Defects Liability Period is: 12 months
Payment Certificates GCC 39.7	A single statement of the estimated value of the work executed shall be submitted on completion of the Works. The Project Manager shall check the statement and certify the amount to be paid to the Contractor.
Payments GCC 40	The amount certified by the Project Manager shall be paid in full within 30 days of receipt by the Employer of an invoice, supported by: (a) the payment certificate; and (b) a certificate of Completion of the Works.
Adverse weather Conditions GCC 41.1 (I)	<i>[Public Entity to define adverse weather conditions]</i>
Price Adjustment GCC 44.	The Contract <i>[is/is not]</i> subject to price adjustment.
Retention GCC 45.	(ii) 10% of the amount shall be retained from any payment. Half of the retention money will be released after formal taking over of the Works and the remaining shall be released after the Defect Liability Period subject to the Contractor making good all defects.*

GCC Clause Reference	Special Conditions
Liquidated Damages GCC 46.1	<p>The liquidated damages for the whole of the Works are <i>[insert rate]</i> per day.</p> <p>The maximum amount of liquidated damages for the whole of the Works is <i>[amount based on a maximum number of days]</i>.</p> <p><i>[Usually liquidated damages are set between 0.05 per cent and 0.10 per cent per day, and the total amount is not to exceed between 5 per cent and 10 per cent of the Contract Price. Alternatively, the daily rate could reflect the actual prejudice that the procuring entity may claim to suffer as direct cost, where applicable or a nominal value taking into consideration the size of the building, nature of construction and the incidence due to non-availability of the building as from the intended completion date. If Sectional Completion and Damages per Section have been agreed, the latter should be specified here.]</i></p>
Advance Payment GCC 48.1	<p>(i) No advance payment shall be made</p>
Performance Security GCC 49.1	<p>(i) No Performance Security is required</p>
GCC 56.1	<p>“As built” drawings or operating and maintenance manuals <i>[insert are or are not]</i> required.</p>
GCC 59.1	<p>The percentage to apply to the value of the work not completed, representing the Employer’s additional cost for completing the Works, is: <i>[insert percentage]</i></p>

SCHEDULE 1:**SCHEDULE 2****QUOTATION CHECKLIST SCHEDULE****Procurement Reference No.:**

Description	Attached	Not Attached
Quotation letter		
Priced Activity Schedules		
Specification and Compliance Sheet		
Bid Securing Declaration		
Bill of Quantities		
Drawings		

Disclaimer: *The list defined above is meant to assist the Bidder in submitting the relevant documents and shall not be a ground for the bidder to justify its non-submission of major documents for its quotation to be responsive. The onus remains on the Bidder to ascertain that it has submitted all the documents that have been requested and are needed for its submission to be complete and responsive.*

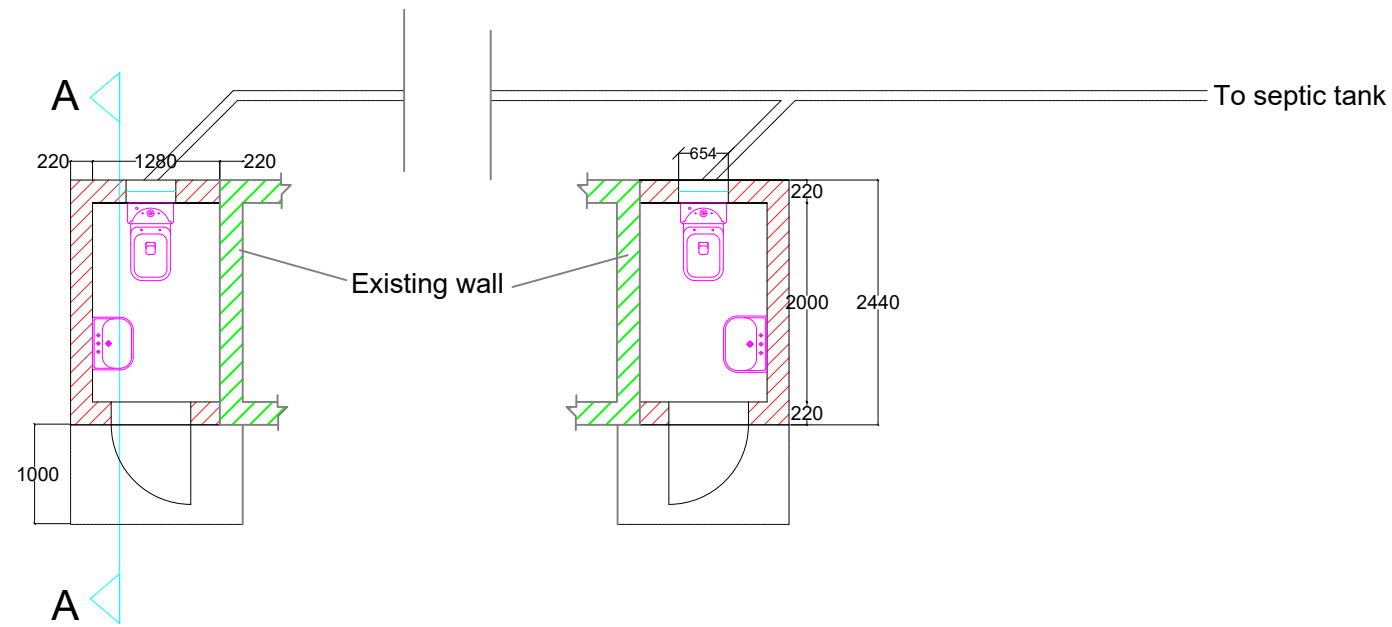

FLOOR PLAN

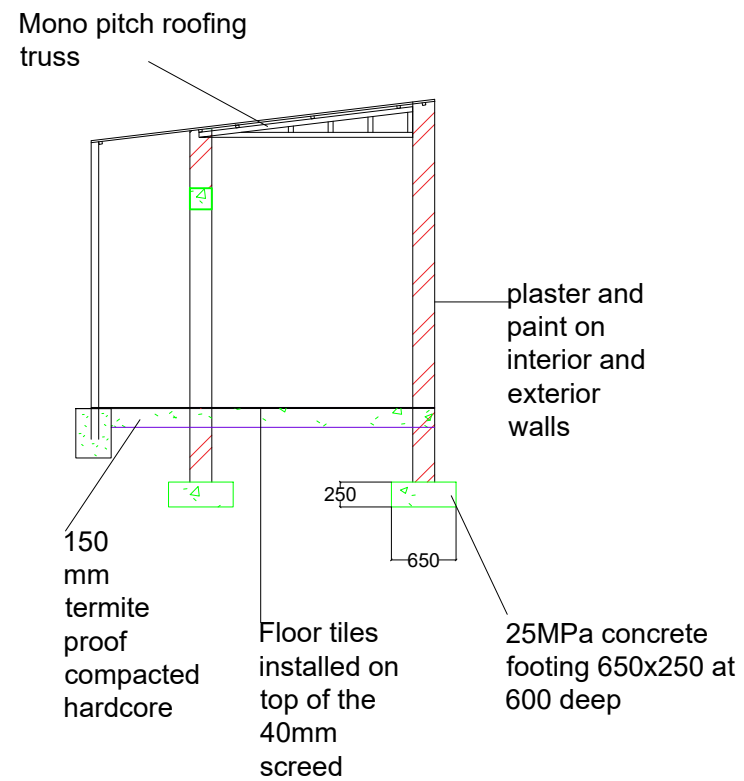

SECTION A-A

Notes

1. Any discrepancies and ambiguous must be reported immediately
2. According to the copyright Act, 1978 (Act No 98 of 1978) no part of this document may be reproduced, stored in a retrieval system or transmitted in any form or by any means whatsoever including mechanical, electronic, photocopying, microfilming or any other system of information storage without written permission.
3. No part of this drawing may be scaled.
4. For actual positions of structures, please consult Ongwediva Town Council.

REVISIONS

No.	Date	Initials	Description
00			

CIVIL/STRUCTURAL ENGINEER:
UNIVERSITY OF NAMIBIA
 Faculty of Engineering and Information
 Technology
 JEDS Campus
 Ongwediva
 Tel: 065 232 4000

CLIENT:
ONGWEDIVA TOWN COUNCIL

PROJECT:
PHASE 1 OTC STADIUM

Approved by _____ Approval Date _____

Drawn by **T MBIZVO** Date **05/11/2021**

Checked by **S SHAANIKA** Date **10/11/2021**

DRAWING TITLE:
TICKETING BOOTH TOILETS

Drawing No: -01	Drawing Scale: 1:	Revision 00
---------------------------	-----------------------------	-----------------------

Notes

1. Any discrepancies and ambiguous must be reported immediately
2. According to the copyright Act, 1978 (Act No 98 of 1978) no part of this document may be reproduced, stored in a retrieval system or transmitted in any form or by any means whatsoever including mechanical, electrical, photocopying, microfilming or any other system of Information storage without written permission.
3. No part of this drawing may be scaled.
4. For actual positions of structures, please consult Ongwediva Town Council.

Window catalogue



Name	NE5
Size	533x654
Location	toilets
Material	steel

REVISIONS

No.	Date	Initials	Description
00			

CIVIL/STRUCTURAL ENGINEER:

UNIVERSITY OF NAMIBIA
 Faculty of Engineering and Information
 Technology
 JEDS Campus
 Ongwediva
 Tel: 065 232 4000

CLIENT:

ONGWEDIVA TOWN COUNCIL

PROJECT:

PHASE 1 OTC STADIUM

Approved by

Approval Date

Drawn by

Date

T MBIZVO

05/11/2021

Checked by

Date

S SHAANIKA

10/11/2021

DRAWING TITLE:

TICKETING BOOTH TOILETS

Drawing No:

-02

Drawing Scale:

1:

Revision

00

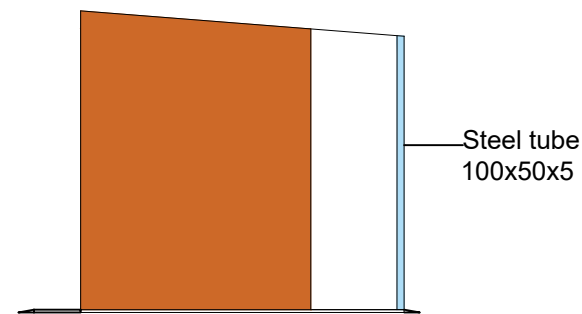

LEFT SIDE VIEW

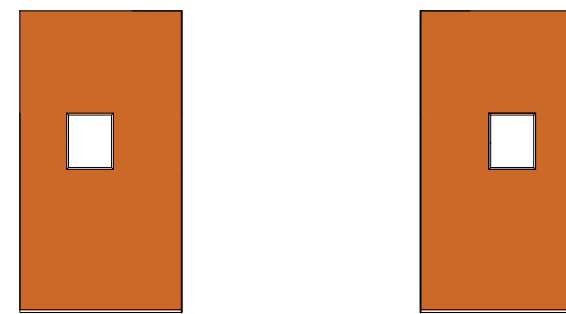

BACK VIEW

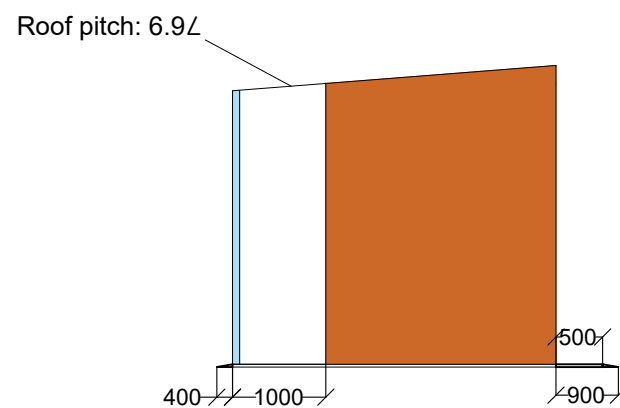

RIGHT SIDE VIEW

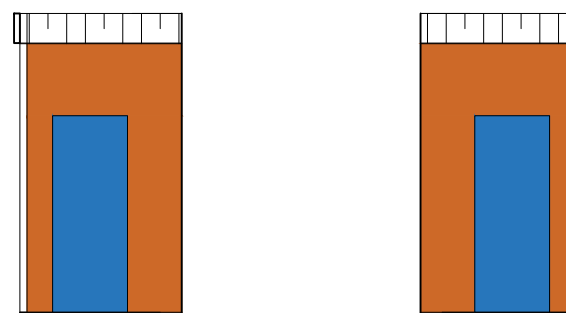

FRONT VIEW

Notes

1. Any discrepancies and ambiguous must be reported immediately
2. According to the copyright Act, 1978 (Act No 98 of 1978) no part of this document may be reproduced, stored in a retrieval system or transmitted in any form or by any means whatsoever including mechanical, electronic, photocopying, microfilming or any other system of Information storage without written permission.
3. No part of this drawing may be scaled.
4. For actual positions of structures, please consult Ongwediva Town Council.

REVISIONS

No.	Date	Initials	Description
00			

CIVIL/STRUCTURAL ENGINEER:
UNIVERSITY OF NAMIBIA
 Faculty of Engineering and Information Technology
 JEDS Campus
 Ongwediva
 Tel: 065 232 4000

CLIENT:
ONGWEDIVA TOWN COUNCIL
 Private Bag 5549 Ongwediva Tel: 065233700 Fax: 065231525

PROJECT:
PHASE 1: ONGWEDIVA SPORTS STADIUM

Approved by _____ Approval Date _____

Drawn by **T MBIZVO** Date **13/09/2021**

Checked by **S SHAANIKA** Date **...../...../2021**

DRAWING TITLE:
SEPTIC TANK & SOAKPIT

Drawing No: **-01** Drawing Scale: **1:100** Revision: **00**

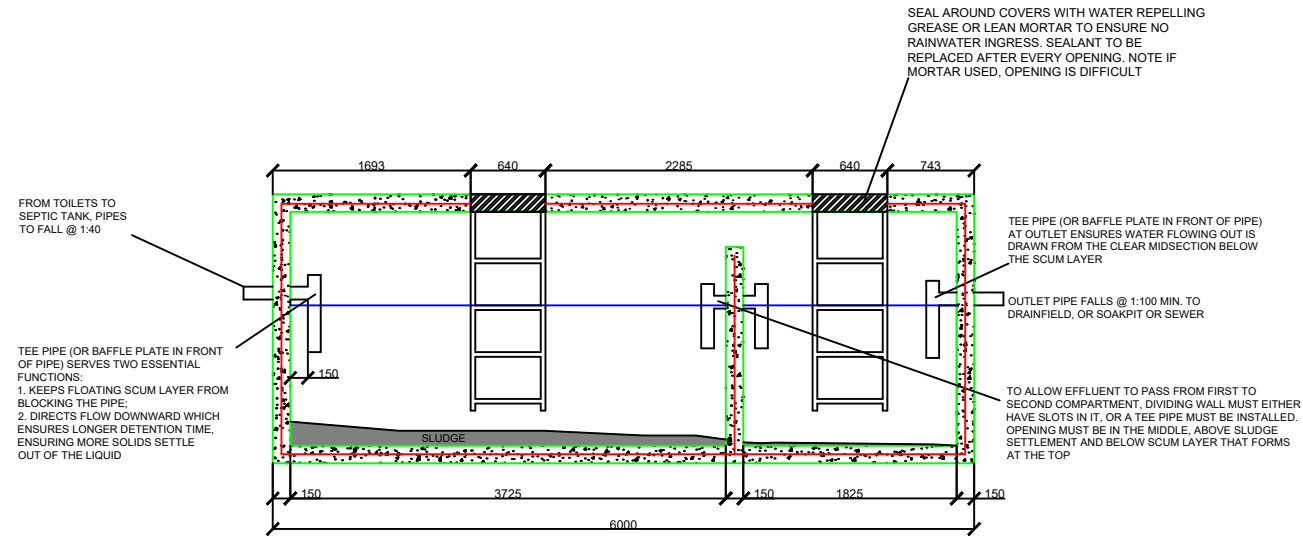

SEPTIC TANK: ELEVATION

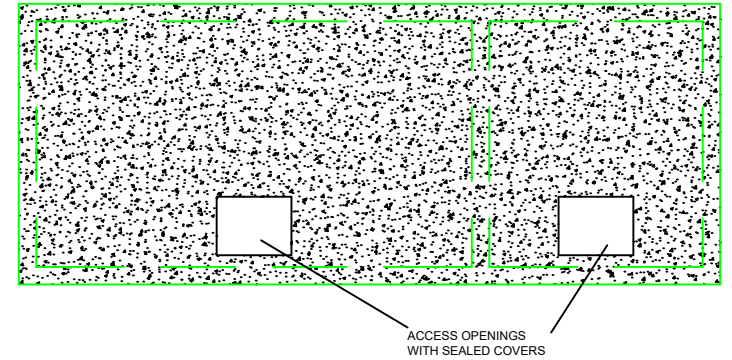
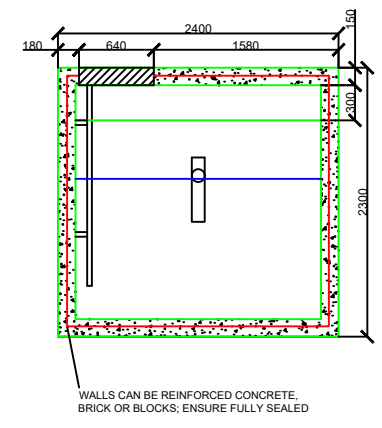

SEPTIC TANK: PLAN

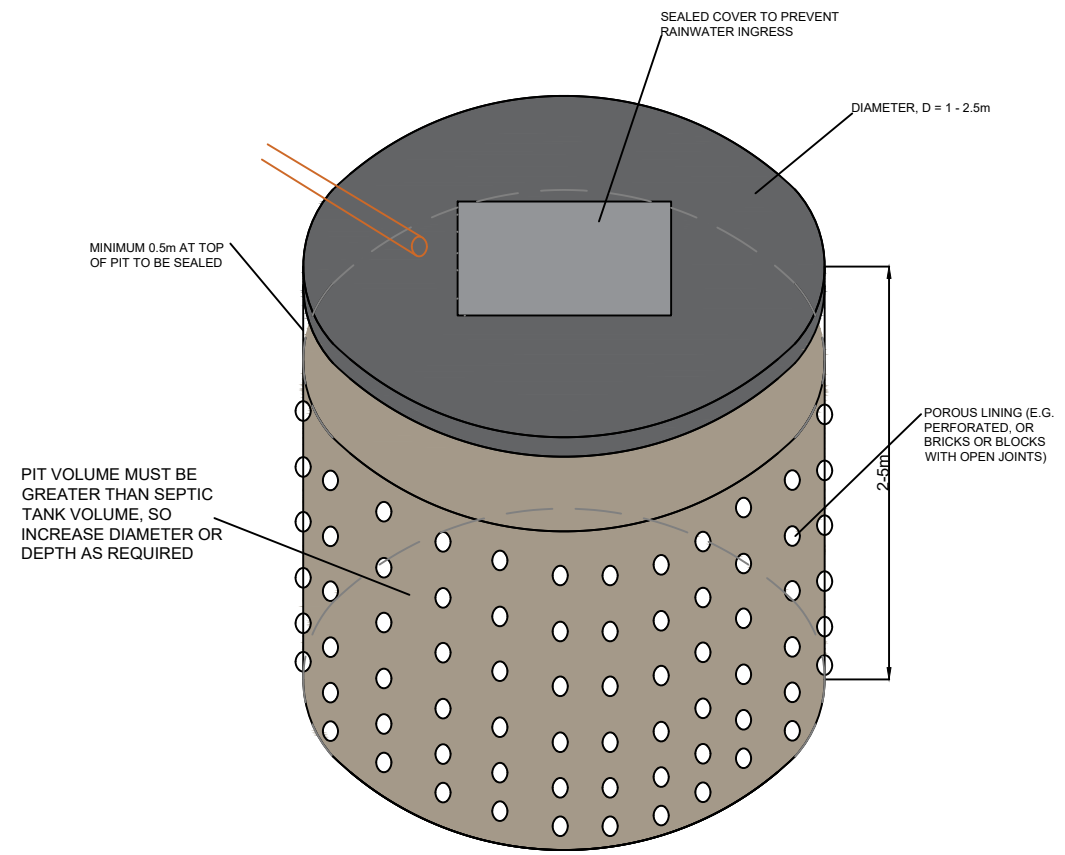

SOAKPIT